

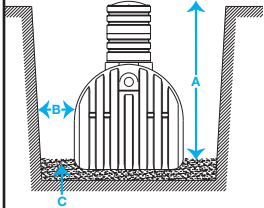

Underground Tank Installation Instructions

1. EXCAVATION



- A.** Excavate to a depth that will provide a minimum of 6" and a maximum of 30" of cover over the top of the tank. This will avoid collapse and over-expansion of the tank and possible leakage.
- B.** Allow 18" to 24" on both sides and both ends of the tank. Failure to comply with allowance ranges could cause tank collapse.
- C.** Bed the tank in well-packed sand – 6" minimum in soil terrain, 12" minimum in rock terrain. The tank should be installed level.

2. SEPTIC TANK CONNECTIONS

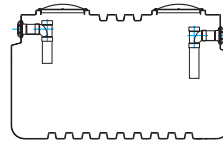

- A.** Septic tanks 750 gallons and larger and blue BRUISER tanks are supplied with PVC sanitary tees and adapters at the inlet and outlet. The PVC adapter has two sockets for use with either 4" schedule 40 pipe or 4" SDR 35 pipe.
- B.** Inlet and outlet piping should be solvent welded to the adapters using standard PVC cement.
- C.** Tanks without PVC adapters (300 sphere, 500 sphere and 500 septic) use Part No. 61765 gasket kit.

3. WATER TANK CONNECTIONS

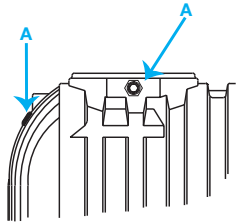

- A.** Install bulkhead fittings in either side of manway or end rib as shown.
- B.** Tank must be vented.
- C.** For water-tight seal, lid should be sealed with silicone caulking. Re-use stainless steel screws supplied with lid.

4. MANHOLE EXTENSIONS

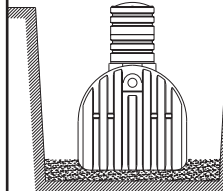

- A.** Install manhole extension before you backfill.
- B.** Manhole extensions are supplied with gaskets and screws. Re-use the lid gasket and screws to attach the lid at the top of the manhole extension.
- C.** Note the direction of flow. The inlet is higher than the outlet.

5. BACKFILLING EXTERIOR

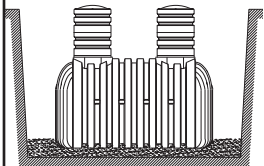

- A. CAUTION:** Fill tank with water as your backfill, keeping water level even with backfill level as you go to prevent possible collapse.
- B.** Backfill with 12" layers and compact each layer. ALWAYS COMPACT ENDS FIRST.
- C.** Tamp and compact backfill under inlet and outlet pipes.
- D.** Maximum backfill over the top of the tank is 30". Mound soil over the top to provide positive drainage.

6. BACKFILL MATERIALS

The preferred material for backfill surrounding and covering the tank is a sand/gravel mixture as described below. For blue BRUISER tanks and white cistern tanks, native soil may be used for backfill and those tanks may be left empty while backfilling. For yellow and black septic tanks, the sand/gravel mixture is required and the tanks must be filled with water during the backfilling process. BRUISER tanks and cistern tanks should be filled one-fourth full after installation.

- A.** The sand/gravel mixture should be a mixture of sand and gravel, 100% smaller than 1½", and about 50% smaller than ¼".
- B.** All fill should be free of any wood, masonry debris, silt or clay.

For septic installations, it is important to contact your local or state sanitarian regarding approved installation procedures.

CAUTION

Failure to comply with the points below voids warranty.

- A.** Do not install any tank in water saturated clay or in a high water table. The tank may collapse and its contents will escape.
- B.** Tanks are not fire-resistant. Do not store them near an open flame or heat in excess of 180°F.
- C.** Do not install any tank under the path of vehicles or heavy equipment.
- D.** If a yellow or black septic tank is pumped for normal maintenance, it should be refilled immediately. If a blue BRUISER tank or a white cistern tank is pumped empty, it should be immediately refilled to one-fourth of capacity. Spherical 300 and 500 gallon tanks may be left empty.
- E.** Norwesco yellow and black septic tanks, blue BRUISER tanks, and cistern tanks are designed only for use as underground tanks.
- F.** Norwesco yellow or black septic tanks, with the exception of the 300 and 500 gallon spherical tanks, cannot be used as holding tanks or pump tanks because the tank may collapse if it is left empty underground.
Blue BRUISER tanks, white cistern tanks, and 300 or 500 gallon spherical tanks can be used for holding or pumping applications where permitted by local codes.
- G.** White cistern tanks and blue BRUISER tanks are made of resins that meet FDA specifications for the storage of drinking water and can be used for that application. Yellow septic tanks and black septic tanks must not be used for drinking water.
- H.** Protect the tank from sharp objects which could puncture it and cause leakage.

***Norwesco advises against the use of a plastic underground tank for any other uses!
Such uses would void any Norwesco product warranty either stated or implied. In no event shall
Norwesco be held liable for any consequential damages.***

WARRANTY

The Norwesco underground tanks, when installed in accordance to manufacturer's instructions, are warranted against defective materials and/or workmanship for a full three (3) years from date of manufacture. Should a defect appear within the warranty period, Norwesco will supply a new, equivalent tank in replacement thereof. Norwesco's liability is limited to the value of the tank itself and specifically excludes the cost of installation and/or removal and consequential damages.



NORWESCO INC.

4365 Steiner Street | P.O. Box 439
St. Bonifacius, MN 55375-0439
TEL (952) 446-1945 | FAX (800) 874-2371

www.norwesco.com



2500 Gallon Below Ground Holding Tank Installation Instructions

THIS TANK IS NOT TO BE USED ABOVE GROUND

1. EXCAVATION

- A. Excavate to a depth that will provide a minimum of 6" and a maximum of 24" of cover over the top of the tank.
- B. Allow 18" to 24" on both sides and both ends of the tank.
- C. Bed the tank in well-compacted sand – 6" minimum in soil terrain, 12" minimum in rock terrain.

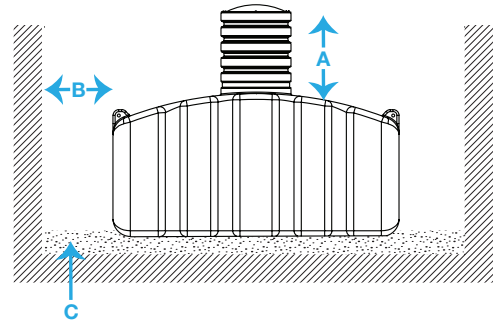

2. CONNECTIONS TO TANK

- A. Install fittings in any location required for holding tank use.
- B. Contact factory for approval if multiple fittings are installed in close proximity.
- C. Tank must be vented.
- D. For water-tight seal, lid should be sealed with silicone or urethane caulking. Re-use stainless steel screws supplied with lid to re-attach lid to tank.

3. MANHOLE EXTENSION

- A. Install manhole extension before you backfill.
- B. Norwesco manhole extensions are supplied with gaskets and screws. Re-use the stainless steel screws to attach the lid at the top of the manhole extension.

4. BACKFILLING EXTERIOR

- A. Backfill with 12" layers and compact each layer. Always compact ends first.
- B. Each of the six interior support cones must be filled and compacted in 6" layers; the bottom half of the cones are tapered and must have the soil compacted to provide structural support. See diagram.
- C. Maximum backfill over the top of the tank is 24". Mound soil over the top to provide positive drainage.

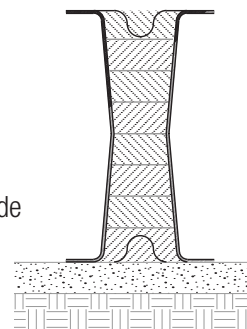

Fill Cones in 6" layers from the bottom up, compact each layer. Use recommended backfill material.

5. BACKFILL MATERIALS

- A. The preferred material for backfilling, surrounding and covering the tank is a sand and gravel mixture—100% smaller than 1½" and approximately 50% smaller than ¼". Native soil can be used if this mixture is not available.
- B. All fill must be free of any wood, masonry debris, silt or clay. Sharp objects must not come in contact with the wall of the tank.

CAUTION

Failure to comply with the points below voids warranty.

- A.** Maximum burial depth is 24 inches.
- B.** Do not install tank in water-saturated clay or in high water table.
- C.** Do not install tank across the path of vehicles or heavy equipment.
- D.** Protect tank from sharp objects which could puncture it and cause leakage.
- E.** Tanks are not fire-resistant. Do not store them near an open flame or in heat in excess of 180° F.
- F.** Do not lift tank by lugs unless tank is empty. Always lift using 4 lugs simultaneously.

***Norwesco advises against the use of a plastic underground tank for any other uses!
Such uses would void any Norwesco product warranty either stated or implied. In no event shall
Norwesco be held liable for any consequential damages.***

WARRANTY

The Norwesco underground tanks, when installed in accordance to manufacturer's instructions, are warranted against defective materials and/or workmanship for a full three (3) years from date of manufacture. Should a defect appear within the warranty period, Norwesco will supply a new, equivalent tank in replacement thereof. Norwesco's liability is limited to the value of the tank itself and specifically excludes the cost of installation and/or removal and consequential damages.



NORWESCO INC.

4365 Steiner Street | P.O. Box 439
St. Bonifacius, MN 55375-0439
TEL (952) 446-1945 | FAX (800) 874-2371

www.norwesco.com